

SGM[®] ILD

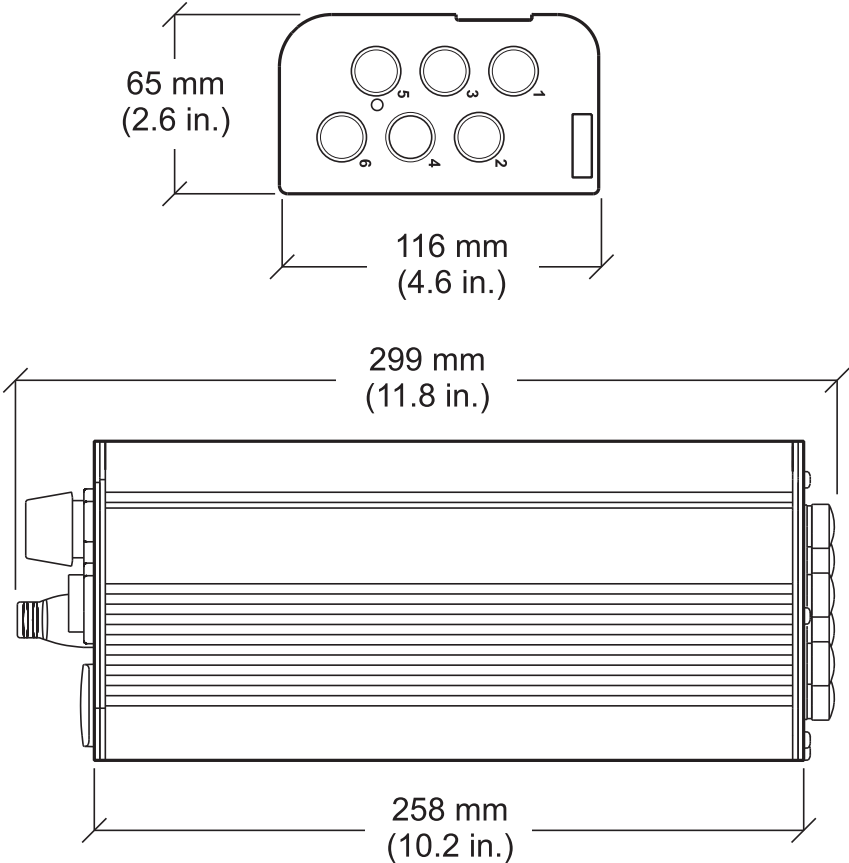

ILD dimensions



*All dimensions in mm.
Drawing not to scale.*

ILD

USER MANUAL REV. 1

© 2012 SGM™. Information subject to change without notice. SGM and all affiliated companies disclaim liability for any injury, damage, direct or indirect loss, consequential or economic loss or any other loss occasioned by the use of, inability to use or reliance on the information contained in this manual. The SGM logo, the SGM name and all other trademarks in this document pertaining to services or products by SGM or its affiliates and subsidiaries are trademarks owned or licensed by SGM or its affiliates or subsidiaries.

English edition

Contents

- Safety information..... 6
- Overview..... 8
- Installing the ILD..... 9
- Connecting AC power..... 11
- Connecting to control data..... 12
- Configuring the device..... 14
- Service..... 16
- Specifications 17

Safety information



WARNING! Read the safety precautions in this section before installing, powering or operating this product.

The ILD is intended for professional use only. It is not suitable for household use.

Review the following safety precautions carefully before installing or operating the device.

Preventing electric shock



DANGER! Risk of electric shock. Do not open the device.

- Do not open the device; there are no user-serviceable parts inside.
- Ensure that power is cut off when wiring the device to the AC mains supply.
- Ensure that the device is electrically connected to earth (ground).
- Do not apply power if the device is in any way damaged.
- Do not immerse the fixture in water or liquid.



WARNING! Take measures to prevent personal injury.

- Install only in a well-ventilated space.
- Do not paint, cover, or modify the device.
- Take precautions to prevent injury due to falls when working at height.
- Ensure that the device is always securely fastened with suitable hardware.
- For elevated installations, always comply with relevant load dimensioning and safety standards and requirements.

Overview

The ILD is an Artnet pixel driver that can be used to drive six SGM LT-100s, three SGM LT-200 or 168 SGM LED Ball pixel luminaires. Up to five ILDs can be configured and controlled when daisy-chained together and connected to a computer using an Ethernet cable, and up to five ILD's per port can be daisy-chained when one or more Ethernet switches are used. ILDs can be configured using the SGM Artnet Configurator (available from <http://www.sgmlight.com>) and controlled using a lighting controller or computer-based Artnet controller.

Unpack the device and inspect it to ensure that it has not been damaged in transport.

The fixture is not designed for permanent outdoor installation, but it is IP65-rated. This means that it is protected from:

- Dust, to the degree that there is no ingress of dust.
- Lower pressure jets of water from any direction.

Installing the ILD



WARNING! Always secure an elevated ILD with a safety cable as backup

The ILD may be installed in any orientation.

Before installing ILDs at elevation, ensure that the:

- Attachment hardware is in good condition and designed to support at least 10 times the fixture's weight.
- Structure can support at least 10 times the weight of all installed fixtures.
- Work area below is blocked from public access and make sure the work is performed from a stable platform.

When using more than one ILD to create an LED curtain, ensure that the ILDs are installed so that the correct pixel pitch can be achieved.

A T-Bolt Bracket is available to support an ILD when bolted to a surface. For other mounting solutions, consult your SGM representative.

T-bolt Bracket

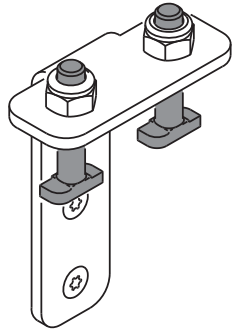

Use two T-Bolt Brackets to attach an ILD to a flat surface. These brackets are secured to the mounting surface using three pieces of M6 hardware. To attach an ILD to a bracket, slide the t-bolts into the attachment rail in the ILD casing (A), turn the bolt 90 degrees so that its head is under the rail rim, and then secure by tightening the nut (B).

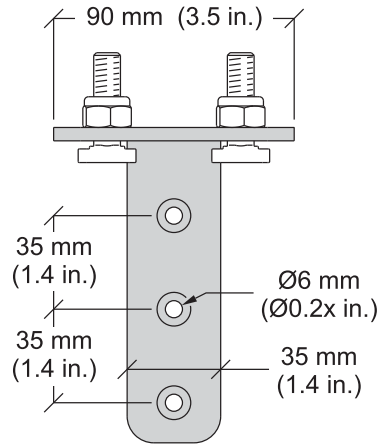
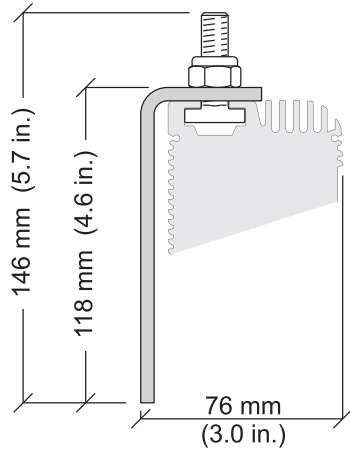
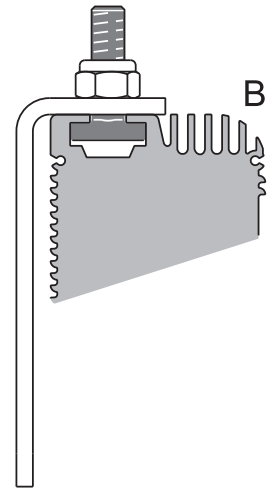
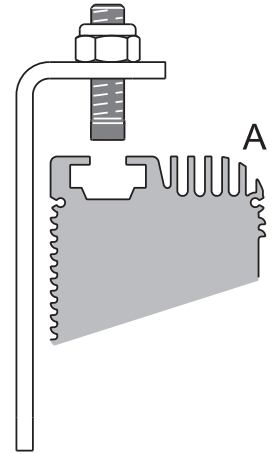

Connecting AC power

The ILD can operate on any 100–240 V, 50/60 Hz AC mains power supply. For temporary installations, install a grounding-type (earthed) industrial 3-pronged type B plug that complies with IEC 60309 or a comparable national standard and is rated 16 A minimum, and use corresponding power outlet sockets. Follow the connector manufacturer’s instructions and all locally applicable laws and electrical safety codes. For permanent installations, have a qualified electrician hard-wire the ILD to the AC mains supply

The device must be grounded/earthed and be able to be isolated from AC power. The AC power supply must incorporate a fuse or circuit breaker for fault protection.

Connecting LED pixels

The ILD is able to drive six SGM LT-100s, three SGM LT-200 or 168 (6 x 28) SGM LED Ball pixel luminaires. These can be attached in any arrangement to the six connectors on the ILD. The six LED pixel connectors on the ILD are not design to bear loads. Always ensure that any attached LT-100s, LT-200s and LED Balls are supported by other means than attachment to an ILD connector.

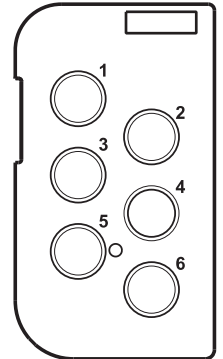

Connecting to control data

The device complies with the Artnet communications protocol. It must be connected to an Artnet compliant LAN (IP addresses in the 2.x.x.x range). Connect the Artnet-in socket to the Artnet compliant LAN using an Ethernet cable with an RJ-45 connector. The ILD can feed control signals to another device in a daisy chain using the Artnet-out socket. Do not daisy-chain more than five ILDs or other driver devices from a single network port or computer, and use an Ethernet switch if more than five ILDs are being configured and controlled.

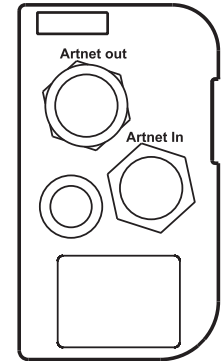
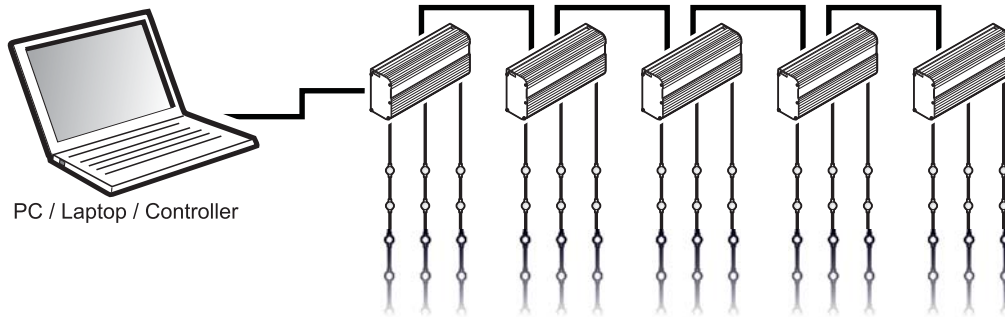

For communication to function, both the ILD and the PC must be on the same local area network (LAN) with IP addresses in the 2.x.x.x range (which are IP addresses used and recognised by Artnet). The PC can be connected directly to an ILD using a network Ethernet cable, and up to five ILDs can be daisy-chained. To connect more than five ILDs, use an Ethernet switch, but do not connect more than five ILDs to each port.

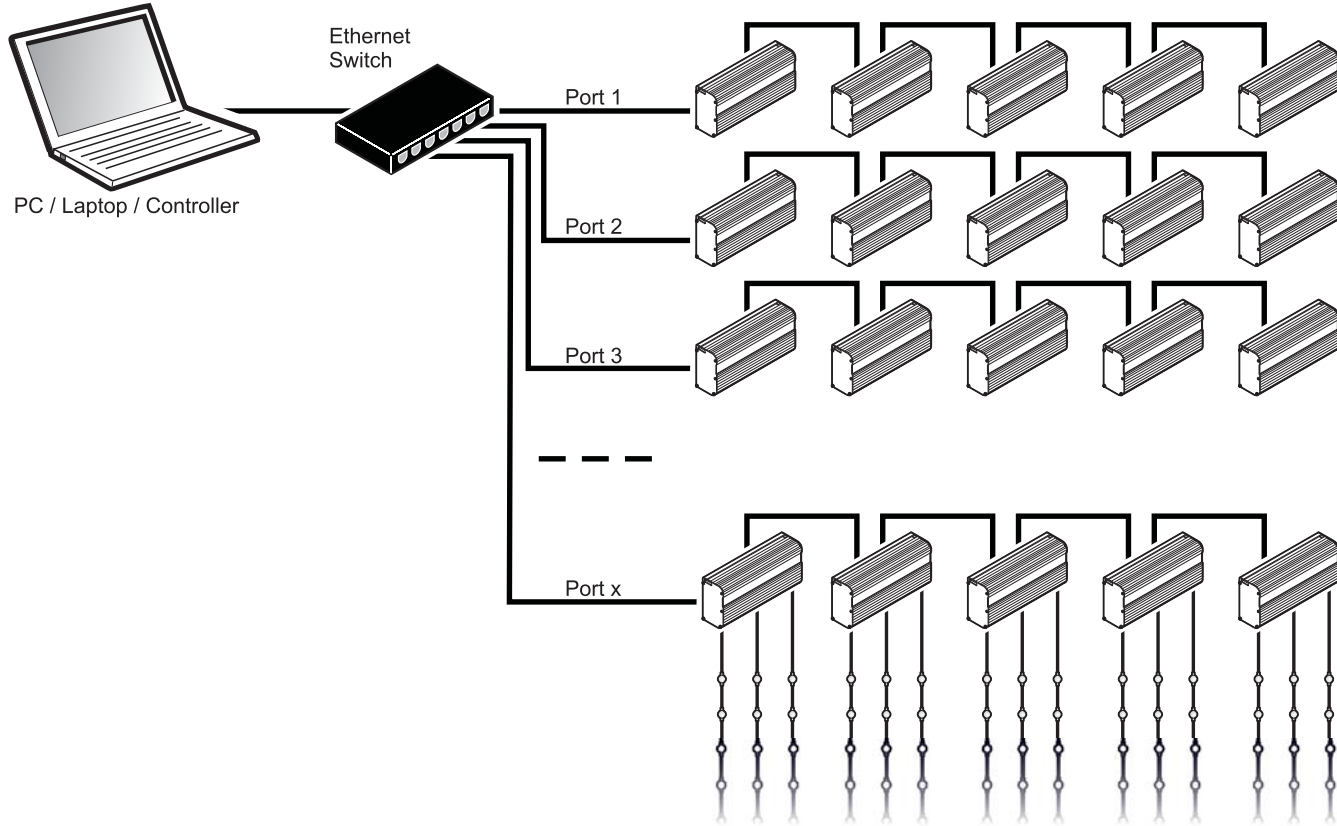

Configuring the device

Configuring the device using the SGM Artnet Configurator

Once pixel luminaries are attached and the ILD is connected to AC power, setup the ILD using the *SGM Artnet Configurator* (available from <http://www.sgmlight.com>). See the *SGM Artnet Configurator User Manual*. The SGM Artnet Configurator is a Windows-based application for configuring and addressing SGM Artnet pixel drivers, such as the ILD. The SGM Artnet Configurator can be used to configure the ILD and assign DMX addresses (with three DMX channels (red, green and blue) to each pixel. The ILD can be configured to address pixels across multiple DMX universes. A highlight function enables testing of the configuration and power measurements are shown. (This is useful for troubleshooting; if too many pixels are attached, performance issues can occur, as an ILD may not supply more than 150 W).

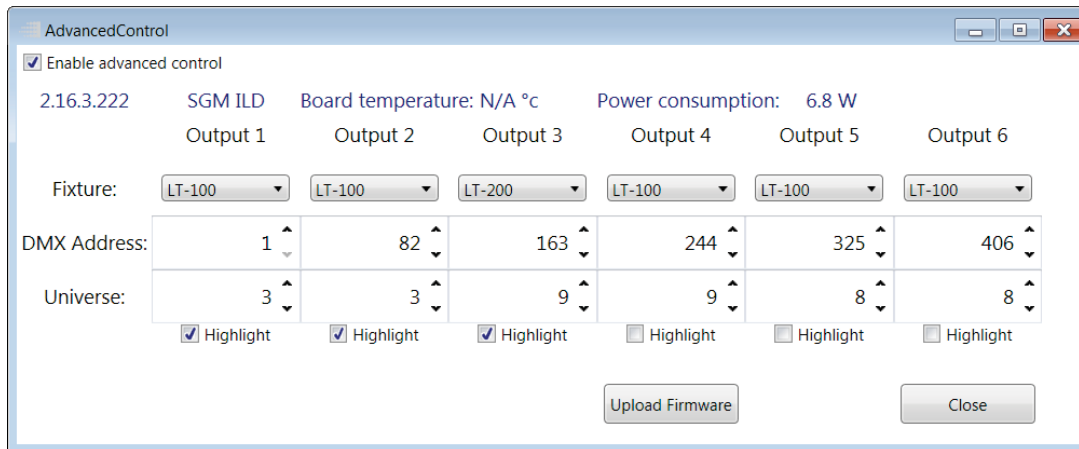

Configuring the device using an Android telephone via RFID

As an alternative to connecting the device to power and using the *SGM Artnet Configurator*, one or more ILD devices can also be configured wirelessly, via RFID, using the SGM Tool app (available from the Google Play Store) installed on an Android smart phone that has NFC support (ISO 15693 and ISO 18000-3 mode 1 compatible, operating on 13.56 MHz \pm 7k Hz carrier frequency).

Service

There are no user-serviceable components inside the device. Do not open the ILD, as doing so is likely to damage its ingress protection. Consult your SGM dealer if the device operates abnormally, is defective or otherwise in need of service or repair.

Upgrading the firmware

We recommend that you to keep your device's firmware current. Visit <http://www.sgmlight.com> to obtain the most up-to-date firmware. To perform firmware updates, you need a Windows personal computer and the SGM Artnet Configurator (available from <http://www.sgmlight.com>).

Specifications

PHYSICAL

Length x width x height 299 x 116 x 65 mm (11.8 x 4.6 x 2.6 in.)

CONSTRUCTION

Housing Steel

FinishBlack

INSTALLATION

Orientation Any

AMBIENT OPERATING CONDITIONS

Maximum ambient temperature (T_a) 40° C (104° F)

Minimum ambient temperature (T_a) -10° C (14° F)

Operating humidity 100%

IP rating IP 65

PROGRAMMING AND CONTROL

Configurationvia PC running SGM Artnet Configurator
Control of attached LED pixels via Artnet with three DMX channels per LED pixel
Software upgrade via PC running SGM Artnet Configurator
Wireless interface via RFID using an Android telephone that has NFC support and SGM Tools app

CONNECTIONS

Artnet data input RJ-45 female socket
Artnet data output RJ-45 female socket
Pixel luminaire connections Six threaded screws, compatible with SGM LT-100, LT-200 and LED Balls

ELECTRICAL

AC power 100–240 V, 50/60 Hz
Maximum total power consumption 150 W

Specifications subject to change without notice



SGM A/S · Soeren Frichs Vej 51-53 · DK 8230 Aabyhoej · Denmark
Tel +45 70 20 74 00 · info@sgmlight.com · www.sgmlight.com