

SGM® Q-2
Q-2 WHITE

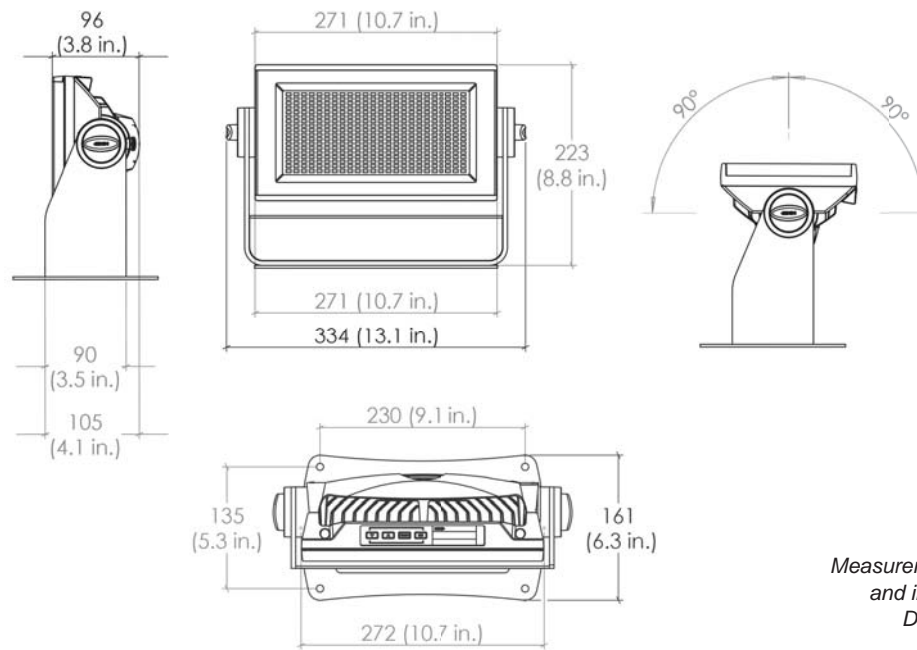

Q-2 / Q-2 W Dimensions



*Measurements in millimetres
and inches (in brackets).
Drawing not to scale.*

Q-2 / Q-2 W USER MANUAL

© 2015 SGM®. Information subject to change without notice. SGM and all affiliated companies disclaim liability for any injury, damage, direct or indirect loss, consequential or economic loss or any other loss occasioned by the use of, inability to use or reliance on the information contained in this manual. The SGM logo, the SGM name and all other trademarks in this document pertaining to services or products by SGM or its affiliates and subsidiaries are trademarks owned or licensed by SGM or its affiliates or subsidiaries.

The original edition of this document is in English. All other language editions are translations of the original edition.

This edition applies to firmware version 1.10 or later.

Ver. B

Contents

Q-2 / Q-2 W Dimensions	2
Safety information	7
Introduction	10
Parts identification and terminology	11
Preparing for installation	12
Installing the Q-2 / Q-2 W	13
Connecting AC power	15
Configuring the fixture	16
Setting a static color manually	17
Using stand-alone operation	18
Connecting to a DMX control device	19

Configuring the fixture for DMX control	20
<i>About DMX</i>	20
<i>Setting the DMX address</i>	20
<i>Setting the DMX mode</i>	21
<i>Full Color Calibration and Color Temperature Correction (Q-2 only)</i>	23
Fixture personality settings	24
<i>Setting the dimming curve</i>	24
<i>Flipping the OLED display</i>	24
<i>Setting the OLED display saver</i>	24
<i>Setting the fan mode</i>	25
Service	26
<i>Upgrading the firmware</i>	26
<i>Cleaning</i>	26
DMX protocols	27
<i>Q-2 DMX protocols</i>	27
<i>Q-2 W DMX protocols</i>	40
Control menu	49
Fixtures and accessories	55
<i>Ordering information</i>	55

User's notes57

Safety information



WARNING! Read the safety precautions in this section before, unpacking, installing, powering or operating this fixture.

The Q-2 / Q-2 W is a multi-environmental fixture with an IP-rating of 65, intended for professional use only. It is not suitable for household use. **Impropre a l'usage domestique.**

Review the following safety precautions carefully before installing or operating the fixture. The fixture must be installed in accordance with the applicable installation code by a person familiar with the construction and operation of the fixture and the hazards involved. **Ce produit doit être installé selon le code d'installation pertinent, par une personne qui connaît bien le produit et son fonctionnement ainsi que les risques inhérent.**

Preventing electric shock



WARNING! Risk of electric shock.

- Always power off/unplug the fixture before removing any covers.
- Ensure that the power is turned off when connecting the fixture to the AC mains supply.
- Ensure that the fixture is electrically connected to earth (ground).
- Do not apply power if the fixture is in any way damaged.
- Do not immerse the fixture in water or liquid.

Preventing burns and fire



WARNING! Take measures to prevent burns and fire.

- Install in a location that prevents accidental contact with the fixture.
- Install only in a well-ventilated space.
- Install at least 0.3 m (12 in.) away from objects to be illuminated.
- Install only in accordance with applicable building codes.
- Ensure a minimum clearance of 0.1 m (4 in.) around the cooling fans.
- Do not paint, cover or modify the fixture.
- Keep all flammable materials away from the fixture.
- Allow the fixture to cool for 15 minutes after operation, before touching it.

CAUTION: *Exterior surface temperature after 5 min. operation = 45°C (113°F). Steady state = 60°C (140°F).*

Avoid personal injury



WARNING! Take measures to prevent personal injury.

- Do not look directly at the light source from close range.
- Take precautions to prevent injury due to falls when working at height.
- For permanent installation, ensure that the fixture is securely fastened to a load-bearing surface with suitable corrosion-resistant hardware.
- For temporary installation with clamps, ensure that the quarter-turn fasteners are turned fully and secured with a suitable safety cable. The cable must be approved for a safe working load (SWL) of 10 times the weight of the fixture, and it must have a minimum gauge of 2 mm.

Introduction

The Q-2 is a low-profile, compact IP65-rated, full-color LED flood light, incorporating 432 RGB + 432 White LEDs divided into 3 individually controllable segments for wide ranging color and effect combinations.

The Q-2 W is a low-profile, compact IP65-rated cool white flood light, incorporating 432 cool white LEDs divided into 12 individually controllable segments for wide ranging effect combinations.

Both fixtures offer dimming, a (half-peak) spread angle of 110°, and a lamp life expectancy of 50,000 hours*. In addition, the Q-2 offers RGBW color mixing and color temperature control.

This manual covers installation, use and maintenance of the Q-2 / Q-2 W. All documentation is also available from the SGM web-site: <http://www.sgmlight.com>

* At 70% of luminous output under the manufacturer's test conditions.

Parts identification and terminology

- A Q-2: 432 RGB + 432 White LEDs
- B Q-2 W: 432 White LEDs
- C Base
- D Tilt brake lock
- E Cooling fan
- F DMX in/out
- G Power connection
- H OLED display
- I Control panel
- J Safety wire eyelet

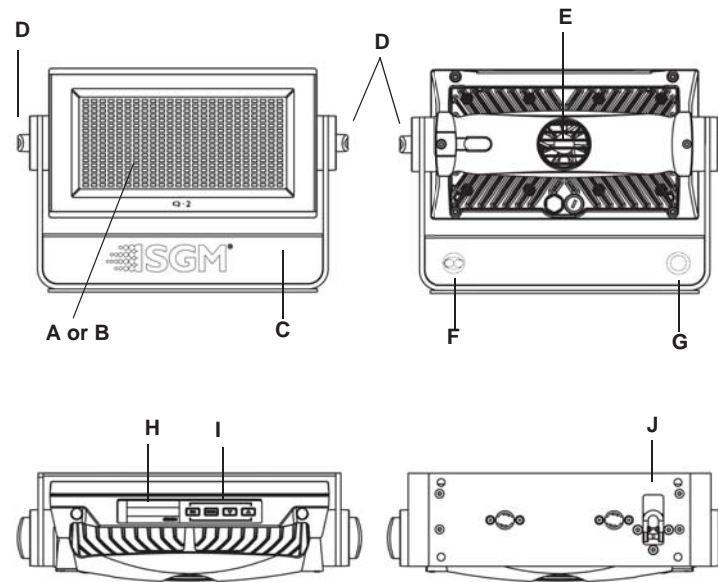

Preparing for installation

Unpack the fixture and inspect it to ensure that it has not been damaged during transport.

The Q-2 series is shipped with an Omega bracket, that can be used to mount the fixture at elevation. The fixture is IP65-rated, and is designed for use in wet locations. This means that it is protected from:

- Dust, to the degree that dust cannot enter the fixture in sufficient quantities as to interfere with its operation.
- Lower pressure jets of water from any direction.

When selecting a location for the fixture, ensure that:

- It is situated away from public thoroughfares and protected from contact with people.
- It is not immersed in water or exposed to high-pressure water jets.
- It has adequate ventilation.

Installing the Q-2 / Q-2 W

The Q-2 / Q-2 W may be installed in any orientation, but if installed horizontally with a downward beam-angle, water can potentially pool in the fan wells. Under normal operation the moisture will evaporate. However, in locations with high rainfall, you may wish to fabricate a rain shield above the fixture, or modify the position and orientation of the fixture to minimize pooling.

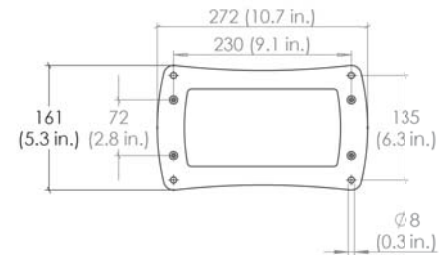

For permanent installation on the ground, remove the rubber feet from the floor stand/base. Fasten securely through the resulting holes with four 6 mm (1/4 in.) corrosion-resistant mechanical fasteners suitable for the location.

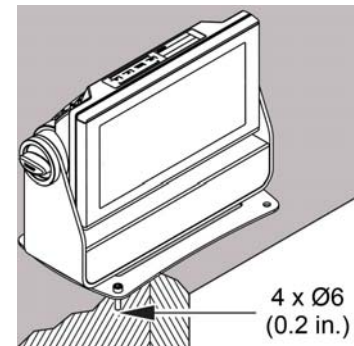

One Omega bracket is supplied with the fixture if it is to be flown above the ground. Remove the floor stand/base and rig the Q-2 / Q-2 W to a support truss or structure using the supplied brackets and suitable clamps.



Fasten a safety cable (not shown) between the support structure and the attachment point on the fixture. The safety cable must be approved for a safe working load (SWL) of 10 times the weight of the fixture.

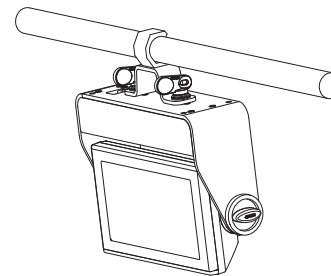

WARNING! Always secure an elevated fixture with a safety cable as backup.

The fixture can be tilted from 0° - 180°. To adjust the tilt angle, loosen the two tilt brake locks, one on each side of the fixture, and tilt the fixture to the angle required and re-tighten the locks.

If installed horizontally with a downward beam-angle, water can potentially pool in the fan wells. Under normal operation the moisture will evaporate.

CAUTION: If the fixture has been operating, always allow it to cool for 15 minutes before handling.

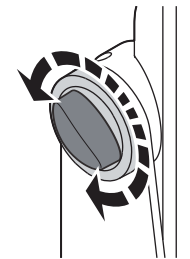

Connecting AC power

The Q-2 / Q-2 W can operate on any 100–277V, 50/60 Hz AC mains power supply. It draws approximately 1.2 amps at full power (230V).

For permanent installation, have a qualified electrician wire the mains cable directly to a suitable branch circuit. The junction's ingress protection (IP) rating must be suitable for the location.

For temporary installation, the mains cable may be fitted with a grounded connector intended for exterior use.

The power cable color coding is given in Table 1-1.

- Connect the black wire to live
- Connect the white wire to neutral
- Connect the green/yellow wire to ground (earth)





Wire	Color	Symbol	Conductor
	Black	L	live
	White	N	neutral
	green/yellow	 or 	ground (earth)

Table 1-1.

The fixture must be grounded/earthed and be able to be isolated from AC power. The AC power supply must incorporate a fuse or circuit breaker for fault protection.

After connecting the Q-2 / Q-2 W to power, run the on-board test, using the "Test→Selftest" menu, to ensure that the fixture and each LED are functioning correctly. See "Control menu" on page 49.

CAUTION: Do not open the fixture to replace the supplied power cable, or connect the fixture to an electrical dimmer system, as this can damage it.

Configuring the fixture

Set up the fixture using the control panel and OLED display at the top of the fixture.

Navigate the menus and options using the arrow buttons and select items using the Enter button. The options available are listed in "Control menu" on page 49.

After powering the Q-2 / Q-2 W on, the display shows the currently selected operating mode and other information.

- A** - Operational mode
- B** - DMX address
- C** - External data indicator (if DMX control is active)
- D** - External data protocol (DMX)

The fixture is set by default to be controlled in DMX mode.

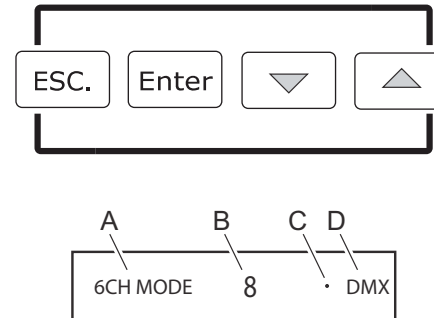

Setting a static color manually

The fixture can be configured to display a predefined and static color using the “Manual→Quick color” menus (see “Control menu” on page 49). Note that whenever the “Manual→Quick color” settings are changed, the fixture will be set by default to automatically start in quick color mode whenever it is powered on. This can be reset using the “Settings→Startup mode→Select startup mode” (see “Control menu” on page 49).

Using stand-alone operation

Stand-alone operation is where the fixture is not connected to a control device, but is preprogrammed with a series of up to 24 scenes, that play continuously in a loop. Up to three stand-alone programs can be defined and run from the menus, and one of the programs can be set to run by default whenever the fixture is started.

Each of the three available stand-alone programs contains 24 user-definable scenes, each scene with its own RGBW (or white) and shutter settings. Each scene has a definable fade-in time, for the transition from one color (or white) to the next, and a wait (static) time, each of up to 999 minutes and 59 seconds in duration. To define a stand-alone program, use the "Manual→Editor" menus (see "Control menu" on page 49).

Stand-alone mode at fixture startup is enabled using the "Settings→Startup mode→Select startup mode→Standalone" menu. The program to be run is selected using "Settings→Startup mode→Startup program" menu (see "Control menu" on page 49) for a description of the menus). The chosen program will run its length cyclically whenever the fixture is powered on.

A program can be run at any time by selecting it using the "Manual→Run program" menu.

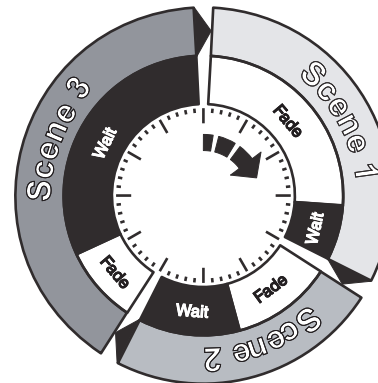

Connecting to a DMX control device

The fixture is controllable using a DMX control device and it can be connected using a DMX cable. If using a cabled DMX system, connect the DMX in cable (with male 5-pin XLR plug) and out cable (with female 5-pin XLR plug) to the DMX data link. Terminate the DMX out cable of the last fixture in the data link. For outdoor installations, use only IP-rated XLR connectors suitable for outdoor use.

Configuring the fixture for DMX control

About DMX

The Q-2 / Q-2 W can be controlled using signals sent by a DMX controller on a number of channels (which varies depending on the DMX mode that has been set).

The first channel used to receive data from a DMX control device is known as the DMX start address. Each Q-2 / Q-2 W must have a DMX start address set. For example, if a Q-2 / Q-2 W has a DMX address of 10 and it is in 3-channel DMX mode, then it uses channels 10, 11, and 12. The following fixture in the DMX chain could then be set to a DMX address of 13. If two or more DMX fixtures of the same type have the same DMX address, then they will mimic each other's behavior. Incorrect settings will result in unpredictable responses to the lighting controller.

Setting the DMX address

The DMX address can be seen on the OLED display. To change the address setting, press the up and down arrows. When the desired address is displayed, press 'Enter' to save the setting. For your convenience, the suggested DMX address of the next fixture is displayed to the right. Note that channel spacing is determined by the DMX mode.

SET DMX ADR	10	NEXT FIX
		13

See the "DMX protocols" on page 27 for specific DMX control values.

Setting the DMX mode

Using the “DMX mode” menu available from the control panel, specify the DMX mode that provides the fixture controls that you require:

Q-2 DMX modes	Function
3	Individual control of color channels for red, green & blue. White is automatically mixed in.
6	RGBW, intensity, shutter, strobe, pulse & open shutter effects.
9	RGB with individual colour panel control.
12	RGB with individual colour panel control, intensity, shutter, strobe, pulse & open shutter effects.
15	RGBW, intensity, shutter, strobe, pulse & open shutter effects.
22	RGB with 16-bit individual colour panel control, intensity, shutter, strobe, pulse & open shutter effects.

Q-2 W DMX modes	Function
1	Full white color control
3	Segmented white color panel control
6	Segmented white color panel control (8-bit or 16-bit)
12	Individual white color panel control
14	Individual white color panel control, intensity, shutter
24	Individual white color panel control (8-bit or 16-bit)

Full Color Calibration and Color Temperature Correction (Q-2 only)

All channel modes except 1 x RGB (3 Channel Mode) and 3 x RGB (9 Channel Mode): Lets you choose between raw or white-calibrated color (2000K - 10.000K) via the CTC channel. When you adjust the white color temperature, all RGB or RGBW channels (if available) must be set to 100%.

1 x RGB (3 Channel Mode) and 3 x RGB (9 Channel Mode): Features full color calibration when you mix 2 or 3 colors to ensure uniform color between products. Adjusting 1 color does not activate full color calibration.

All channel modes except 1 x RGB (3 Channel Mode) and 3 x RGB (9 Channel Mode)	1 x RGB (3 Channel Mode)	3 x RGB (9 Channel Mode)
Choose raw or white-calibrated color (2000K - 10.000K) via the CTC channel. NOTE: When you adjust the white color temperature, all RGB or RGBW channels (if available) channels must be set to 100%.	Full Color Calibration	Full Color Calibration

See "DMX protocols" on page 27 for more details.

Fixture personality settings

Setting the dimming curve

The setting of the dimming curve will determine the fixture's behavior, when changing the light intensity between 0% - 100%. Linear control provides uniform adjustment throughout the control action, whereas gamma corrected dimming provides finer control at low light levels, where the eye is more sensitive to change. By default, the Q-2 / Q-2 W uses gamma corrected dimming. For uniform response, set all fixtures to the same dimming curve. To set the desired dimming curve, use the "Settings→Dimming curve" menu.

Flipping the OLED display

If the fixture is installed hanging upside down, it might be useful to flip the display so that it is easier to read. To flip the display, use the "Settings→Flip display" menu, or press the up and down buttons on the control panel at the same time.

Setting the OLED display saver

By default the OLED display dims down after a short period when the control panel is not in use, but it can also be set to turn off completely. Pressing any key will always turn on the display or restore it to normal brightness. To change the display saver, use the "Settings→Display saver" menu.

NOTE: To avoid the risk of display deterioration caused by long term use in permanent installations, it is recommended to use the "Display saver→Display off" setting.

Setting the fan mode

For operating environments where low-noise is a requirement or where the fixture will be operating in high temperatures, it is possible to adjust the default fan speed to low or high using the “Settings→Fan mode” menu.

Service

There are no user-serviceable components in the fixture. Do not open the Q-2 / Q-2 W, as doing so is likely to damage the ingress protection. Consult your SGM dealer if the fixture operates abnormally, is defective or otherwise in need of service or repair.

Upgrading the firmware

The firmware installed on the fixture can be identified using the "Info→Firmware version" menu. We recommend that you keep your fixture's firmware up-to-date. Visit <http://www.sgmlight.com> to download the latest firmware.

To perform firmware updates, you need a Windows-based personal computer and a SGM USB 5-Pin-XLR upload cable (available from your SGM distributor).

Cleaning

To maintain optimal performance, regular cleaning is essential. Cleaning schedules will vary depending on the operating environment, and the installation should therefore be checked at frequent intervals within the first few weeks of operation to see whether cleaning is necessary. This procedure will allow you to assess cleaning requirements in your particular situation. If in doubt, consult your SGM dealer for a suitable maintenance schedule.

Clean the Q-2 /Q-2 W using a soft cloth dampened with a solution of water and a mild detergent. Do not use products that contain solvents, abrasives or caustic agents for cleaning, as they can cause damage to both hardware, cables and connectors.

DMX protocols

Configuring DMX is described in "Setting the DMX mode" on page 21. This section contains "Q-2 DMX protocols" (below), and "Q-2 W DMX protocols" on page 40

Q-2 DMX protocols

15 Channel Mode (RAW) - Full RGBW control (3 segments)

Channel	Name	DMX value	DMX percentage	Description	Info	Default DMX value	Fader type
1	Shutter	0 7	0,0% 2,7%	Closed		10 (3,9%)	Snap
		8 15	3,1% 5,9%	Open		0 (0%)	Fade
		16 151	6,3% 59,2%	Strobe	Fast > Slow	0 (0%)	Fade
		152 175	59,6% 68,6%	Pulse - Open	Slow > Fast	0 (0%)	Fade
		176 199	69,0% 78,0%	Pulse - Close	Slow > Fast	0 (0%)	Fade
		200 244	78,4% 95,7%	Strobe - Random	Slow > Fast	0 (0%)	Fade
		245 255	96,1% 100,0%	Open		0 (0%)	Fade
2	Intensity	0 255	0,0% 100,0%	No light > Maximum light		0 (0%)	Fade

Channel	Name	DMX value	DMX percentage	Description	Info	Default DMX value	Fader type
3	CTC	0 255	0,0% 100,0%	2000K - 10000K	Only active when channel > 4	0 (0%)	Fade
4	RED Panel 1	0 255	0,0% 100,0%	No RED > Maximum RED	Panel 1	0 (0%)	Fade
5	GREEN Panel 1	0 255	0,0% 100,0%	No GREEN > Maximum GREEN	Panel 1	0 (0%)	Fade
6	BLUE Panel 1	0 255	0,0% 100,0%	No BLUE > Maximum BLUE	Panel 1	0 (0%)	Fade
7	WHITE Panel 1	0 255	0,0% 100,0%	No WHITE > Maximum WHITE	Panel 1	0 (0%)	Fade
8	RED Panel 2	0 255	0,0% 100,0%	No RED > Maximum RED	Panel 2	0 (0%)	Fade
9	GREEN Panel 2	0 255	0,0% 100,0%	No GREEN > Maximum GREEN	Panel 2	0 (0%)	Fade

Channel	Name	DMX value	DMX percentage	Description	Info	Default DMX value	Fader type
10	BLUE Panel 2	0 255	0,0% 100,0%	No BLUE > Maximum BLUE	Panel 2	0 (0%)	Fade
11	WHITE Panel 2	0 255	0,0% 100,0%	No WHITE > Maximum WHITE	Panel 2	0 (0%)	Fade
12	RED Panel 3	0 255	0,0% 100,0%	No RED > Maximum RED	Panel 3	0 (0%)	Fade
13	GREEN Panel 3	0 255	0,0% 100,0%	No GREEN > Maximum GREEN	Panel 3	0 (0%)	Fade
14	BLUE Panel 3	0 255	0,0% 100,0%	No BLUE > Maximum BLUE	Panel 3	0 (0%)	Fade
15	WHITE Panel 3	0 255	0,0% 100,0%	No WHITE > Maximum WHITE	Panel 3	0 (0%)	Fade

12 Channel mode - RGB (raw or white calibrated - 3 segments)

Channel	Name	DMX value	DMX percentage	Description	Info	Default DMX value	Fader type
1	Shutter	0 7	0,0% 2,7%	Closed		10 (3,9%)	Snap
		8 15	3,1% 5,9%	Open		0 (0%)	Fade
		16 151	6,3% 59,2%	Strobe	Fast > Slow	0 (0%)	Fade
		152 175	59,6% 68,6%	Pulse - Open	Slow > Fast	0 (0%)	Fade
		176 199	69,0% 78,0%	Pulse - Close	Slow > Fast	0 (0%)	Fade
		200 244	78,4% 95,7%	Strobe - Random	Slow > Fast	0 (0%)	Fade
		245 255	96,1% 100,0%	Open		0 (0%)	Fade
2	Intensity	0 255	0,0% 100,0%	No light > Maximum light		0 (0%)	Fade
3	CTC	0 255	0,0% 100,0%	2000K - 10000K	Only active when channel > 4	0 (0%)	Fade

Channel	Name	DMX value	DMX percentage	Description	Info	Default DMX value	Fader type
4	RED Panel 1	0 255	0,0% 100,0%	No RED > Maximum RED	Panel 1	0 (0%)	Fade
5	GREEN Panel 1	0 255	0,0% 100,0%	No GREEN > Maximum GREEN	Panel 1	0 (0%)	Fade
6	BLUE Panel 1	0 255	0,0% 100,0%	No BLUE > Maximum BLUE	Panel 1	0 (0%)	Fade
7	RED Panel 2	0 255	0,0% 100,0%	No RED > Maximum RED	Panel 2	0 (0%)	Fade
8	GREEN Panel 2	0 255	0,0% 100,0%	No GREEN > Maximum GREEN	Panel 2	0 (0%)	Fade
9	BLUE Panel 2	0 255	0,0% 100,0%	No BLUE > Maximum BLUE	Panel 2	0 (0%)	Fade
10	RED Panel 3	0 255	0,0% 100,0%	No RED > Maximum RED	Panel 3	0 (0%)	Fade

Channel	Name	DMX value	DMX percentage	Description	Info	Default DMX value	Fader type
11	GREEN Panel 3	0 255	0,0% 100,0%	No GREEN > Maximum GREEN	Panel 3	0 (0%)	Fade
12	BLUE Panel 3	0 255	0,0% 100,0%	No BLUE > Maximum BLUE	Panel 3	0 (0%)	Fade

22 Channel Mode - 16 bit (raw or white-calibrated - 3 segments)

Channel	Name	DMX value	DMX percentage	Description	Info	Default DMX value	Fader type
1	Shutter	0 7	0,0% 2,7%	Closed		10 (3,9%)	Snap
		8 15	3,1% 5,9%	Open		0 (0%)	Fade
		16 151	6,3% 59,2%	Strobe	Fast > Slow	0 (0%)	Fade
		152 175	59,6% 68,6%	Pulse - Open	Slow > Fast	0 (0%)	Fade
		176 199	69,0% 78,0%	Pulse - Close	Slow > Fast	0 (0%)	Fade
		200 244	78,4% 95,7%	Strobe - Random	Slow > Fast	0 (0%)	Fade
		245 255	96,1% 100,0%	Open		0 (0%)	Fade
2 3	Intensity	0 65535	0,0% 100,0%	No light > Maximum light		0 (0%)	Fade
4	CTC	0 255	0,0% 100,0%	2000K - 10000K	Only active when channel > 4	0 (0%)	Fade

Channel	Name	DMX value	DMX percentage	Description	Info	Default DMX value	Fader type
5 6	RED Panel 1	0 65535	0,0% 100,0%	No RED > Maximum RED	Panel 1	0 (0%)	Fade
7 8	GREEN Panel 1	0 65535	0,0% 100,0%	No GREEN > Maximum GREEN	Panel 1	0 (0%)	Fade
9 10	BLUE Panel 1	0 65535	0,0% 100,0%	No BLUE > Maximum BLUE	Panel 1	0 (0%)	Fade
11 12	RED Panel 2	0 65535	0,0% 100,0%	No RED > Maximum RED	Panel 2	0 (0%)	Fade
13 14	GREEN Panel 2	0 65535	0,0% 100,0%	No GREEN > Maximum GREEN	Panel 2	0 (0%)	Fade
15 16	BLUE Panel 2	0 65535	0,0% 100,0%	No BLUE > Maximum BLUE	Panel 2	0 (0%)	Fade
17 18	RED Panel 3	0 65535	0,0% 100,0%	No RED > Maximum RED	Panel 3	0 (0%)	Fade

Channel	Name	DMX value	DMX percentage	Description	Info	Default DMX value	Fader type
19 20	GREEN Panel 3	0 65535	0,0% 100,0%	No GREEN > Maximum GREEN	Panel 3	0 (0%)	Fade
21 22	BLUE Panel 3	0 65535	0,0% 100,0%	No BLUE > Maximum BLUE	Panel 3	0 (0%)	Fade

6 Channel Mode (raw or white calibrated - 1 segment)

Channel	Name	DMX value	DMX percentage	Description	Info	Default DMX value	Fader type
1	Shutter	0 7	0,0% 2,7%	Closed		10 (3,9%)	Snap
		8 15	3,1% 5,9%	Open		0 (0%)	Fade
		16 151	6,3% 59,2%	Strobe	Fast > Slow	0 (0%)	Fade
		152 175	59,6% 68,6%	Pulse - Open	Slow > Fast	0 (0%)	Fade
		176 199	69,0% 78,0%	Pulse - Close	Slow > Fast	0 (0%)	Fade
		200 244	78,4% 95,7%	Strobe - Random	Slow > Fast	0 (0%)	Fade
		245 255	96,1% 100,0%	Open		0 (0%)	Fade
2	Intensity	0 255	0,0% 100,0%	No light > Maximum light		0 (0%)	Fade
3	CTC	0 255	0,0% 100,0%	2000K - 10000K	Only active when channel > 4	0 (0%)	Fade

Channel	Name	DMX value	DMX percentage	Description	Info	Default DMX value	Fader type
4	RED All Panels	0 255	0,0% 100,0%	No RED > Maximum RED	All Panels	0 (0%)	Fade
5	GREEN All Panels	0 255	0,0% 100,0%	No GREEN > Maximum GREEN	All Panels	0 (0%)	Fade
6	BLUE All Panels	0 255	0,0% 100,0%	No BLUE > Maximum BLUE	All Panels	0 (0%)	Fade

9 Channel Mode - 3 x RGB (Full Color Calibration - 3 segments)

Channel	Name	DMX value	DMX percentage	Description	Info	Default DMX value	Fader type
1	RED Panel 1	0 255	0,0% 100,0%	No RED > Maximum RED	Panel 1	0 (0%)	Fade
2	GREEN Panel 1	0 255	0,0% 100,0%	No GREEN > Maximum GREEN	Panel 1	0 (0%)	Fade
3	BLUE Panel 1	0 255	0,0% 100,0%	No BLUE > Maximum BLUE	Panel 1	0 (0%)	Fade
4	RED Panel 2	0 255	0,0% 100,0%	No RED > Maximum RED	Panel 2	0 (0%)	Fade
5	GREEN Panel 2	0 255	0,0% 100,0%	No GREEN > Maximum GREEN	Panel 2	0 (0%)	Fade
6	BLUE Panel 2	0 255	0,0% 100,0%	No BLUE > Maximum BLUE	Panel 2	0 (0%)	Fade
7	RED Panel 3	0 255	0,0% 100,0%	No RED > Maximum RED	Panel 3	0 (0%)	Fade

Channel	Name	DMX value	DMX percentage	Description	Info	Default DMX value	Fader type
8	GREEN Panel 3	0 255	0,0% 100,0%	No GREEN > Maximum GREEN	Panel 3	0 (0%)	Fade
9	BLUE Panel 3	0 255	0,0% 100,0%	No BLUE > Maximum BLUE	Panel 3	0 (0%)	Fade

3 Channel Mode - 1 x RGB (Full Color Calibration - 1 segment)

Channel	Name	DMX value	DMX percentage	Description	Info	Default DMX value	Fader type
1	RED All Panels	0 255	0,0% 100,0%	No RED > Maximum RED	Panel 1	0 (0%)	Fade
2	GREEN All Panels	0 255	0,0% 100,0%	No GREEN > Maximum GREEN	Panel 1	0 (0%)	Fade
3	BLUE All Panels	0 255	0,0% 100,0%	No BLUE > Maximum BLUE	Panel 1	0 (0%)	Fade

Q-2 W DMX protocols

Configuring DMX is described in "Setting the DMX mode" on page 21.

14 Channel Mode - 8 bit (12 segments)

Channel	Name	DMX value	DMX percentage	Description	Info	Default DMX value	Fader type
1	Shutter	0 7	0,0% 2,7%	Closed		10 (3,9%)	Snap
		8 15	3,1% 5,9%	Open		0 (0%)	Fade
		16 151	6,3% 59,2%	Strobe	Fast > Slow	0 (0%)	Fade
		152 175	59,6% 68,6%	Pulse - Open	Slow > Fast	0 (0%)	Fade
		176 199	69,0% 78,0%	Pulse - Close	Slow > Fast	0 (0%)	Fade
		200 244	78,4% 95,7%	Strobe - Random	Slow > Fast	0 (0%)	Fade
		245 255	96,1% 100,0%	Open		0 (0%)	Fade
2	Intensity	0 255	0,0% 100,0%	No light > Maximum light		0 (0%)	Fade
3	Panel 1	0 255	0,0% 100,0%	No light > Maximum light	Panel 1		

Channel	Name	DMX value	DMX percentage	Description	Info	Default DMX value	Fader type
4	Panel 2	0 255	0,0% 100,0%	No light > Maximum light	Panel 2	0 (0%)	Fade
5	Panel 3	0 255	0,0% 100,0%	No light > Maximum light	Panel 3	0 (0%)	Fade
6	Panel 4	0 255	0,0% 100,0%	No light > Maximum light	Panel 4	0 (0%)	Fade
7	Panel 5	0 255	0,0% 100,0%	No light > Maximum light	Panel 5	0 (0%)	Fade
8	Panel 6	0 255	0,0% 100,0%	No light > Maximum light	Panel 6	0 (0%)	Fade
9	Panel 7	0 255	0,0% 100,0%	No light > Maximum light	Panel 7	0 (0%)	Fade
10	Panel 8	0 255	0,0% 100,0%	No light > Maximum light	Panel 8	0 (0%)	Fade

Channel	Name	DMX value	DMX percentage	Description	Info	Default DMX value	Fader type
11	Panel 9	0 255	0,0% 100,0%	No light > Maximum light	Panel 9	0 (0%)	Fade
12	Panel 10	0 255	0,0% 100,0%	No light > Maximum light	Panel 10	0 (0%)	Fade
13	Panel 11	0 255	0,0% 100,0%	No light > Maximum light	Panel 11	0 (0%)	Fade
14	Panel 12	0 255	0,0% 100,0%	No light > Maximum light	Panel 12	0 (0%)	Fade

12 Channel Mode - 8 bit (12 segments)

Channel	Name	DMX value	DMX percentage	Description	Info	Default DMX value	Fader type
1	Panel 1	0 255	0,0% 100,0%	No light > Maximum light	Panel 1		
2	Panel 2	0 255	0,0% 100,0%	No light > Maximum light	Panel 2	0 (0%)	Fade
3	Panel 3	0 255	0,0% 100,0%	No light > Maximum light	Panel 3	0 (0%)	Fade
4	Panel 4	0 255	0,0% 100,0%	No light > Maximum light	Panel 4	0 (0%)	Fade
5	Panel 5	0 255	0,0% 100,0%	No light > Maximum light	Panel 5	0 (0%)	Fade
6	Panel 6	0 255	0,0% 100,0%	No light > Maximum light	Panel 6	0 (0%)	Fade
7	Panel 7	0 255	0,0% 100,0%	No light > Maximum light	Panel 7	0 (0%)	Fade

Channel	Name	DMX value	DMX percentage	Description	Info	Default DMX value	Fader type
8	Panel 8	0 255	0,0% 100,0%	No light > Maximum light	Panel 8	0 (0%)	Fade
9	Panel 9	0 255	0,0% 100,0%	No light > Maximum light	Panel 9	0 (0%)	Fade
10	Panel 10	0 255	0,0% 100,0%	No light > Maximum light	Panel 10	0 (0%)	Fade
11	Panel 11	0 255	0,0% 100,0%	No light > Maximum light	Panel 11	0 (0%)	Fade
12	Panel 12	0 255	0,0% 100,0%	No light > Maximum light	Panel 12	0 (0%)	Fade

24 Channel Mode - 16 bit (12 segments)

Channel	Name	DMX value	DMX percentage	Description	Info	Default DMX value	Fader type
1 2	Panel 1	0 65535	0,0% 100,0%	No light > Maximum light	Panel 1	0 (0%)	Fade
3 4	Panel 2	0 65535	0,0% 100,0%	No light > Maximum light	Panel 2	0 (0%)	Fade
5 6	Panel 3	0 65535	0,0% 100,0%	No light > Maximum light	Panel 3	0 (0%)	Fade
7 8	Panel 4	0 65535	0,0% 100,0%	No light > Maximum light	Panel 4	0 (0%)	Fade
9 10	Panel 5	0 65535	0,0% 100,0%	No light > Maximum light	Panel 5	0 (0%)	Fade
11 12	Panel 6	0 65535	0,0% 100,0%	No light > Maximum light	Panel 6	0 (0%)	Fade
13 14	Panel 7	0 65535	0,0% 100,0%	No light > Maximum light	Panel 7	0 (0%)	Fade

Channel	Name	DMX value	DMX percentage	Description	Info	Default DMX value	Fader type
15 16	Panel 8	0 65535	0,0% 100,0%	No light > Maximum light	Panel 8	0 (0%)	Fade
17 18	Panel 9	0 65535	0,0% 100,0%	No light > Maximum light	Panel 9	0 (0%)	Fade
19 20	Panel 10	0 65535	0,0% 100,0%	No light > Maximum light	Panel 10	0 (0%)	Fade
21 22	Panel 11	0 65535	0,0% 100,0%	No light > Maximum light	Panel 11	0 (0%)	Fade
23 24	Panel 12	0 65535	0,0% 100,0%	No light > Maximum light	Panel 12	0 (0%)	Fade

1 Channel Mode - 8 bit (1 segment)

Channel	Name	DMX value	DMX percentage	Description	Info	Default DMX value	Fader type
1	Intensity	0 255	0,0% 100,0%	No light > Maximum light	All Panels	0 (0%)	Fade

3 Channel Mode - 8 bit (3 segments)

Channel	Name	DMX value	DMX percentage	Description	Info	Default DMX value	Fader type
1	Intensity	0 255	0,0% 100,0%	No light > Maximum light	Left 4 Panels	0 (0%)	Fade
2	Intensity	0 255	0,0% 100,0%	No light > Maximum light	Center 4 Panels	0 (0%)	Fade
3	Intensity	0 255	0,0% 100,0%	No light > Maximum light	Right 4 Panels	0 (0%)	Fade

6 Channel Mode - 16 bit (3 segments)

Channel	Name	DMX value	DMX percentage	Description	Info	Default DMX value	Fader type
1 2	Intensity	0 65535	0,0% 100,0%	No light > Maximum light	Left 4 Panels	0 (0%)	Fade
3 4	Intensity	0 65535	0,0% 100,0%	No light > Maximum light	Center 4 Panels	0 (0%)	Fade
5 6	Intensity	0 65535	0,0% 100,0%	No light > Maximum light	Right 4 Panels	0 (0%)	Fade

Control menu

Level 1	Level 2	Level 3	Level 4	Function
MODE	SELECT MODE	-	-	Select DMX mode.
INFO	PRODUCT TYPE	-	-	Displays product type.
	FIRMWARE VERSION	-	-	Displays software version.
	SERIAL NUMBER	-	-	Displays serial number.
	RDM ID	-	-	Displays RDM ID.
	DMX VIEW	-	-	Displays received DMX channels.
	TEMPERATURES	-	-	Displays temperatures (mainboard, left, center and right LED panel).
	POWER ON TIME	-	-	Displays fixture lifetime.
	LED ON TIME	-	-	Displays LED lifetime.
	LOG	-	-	Displays recorded operation data and error codes.

Level 1	Level 2	Level 3	Level 4	Function
SETTINGS	STARTUP MODE	SELECT STARTUP MODE	DMX STANDALONE QUICK COLOR	Default operation mode when the fixture is powered on. Stand-alone program 1, 2, or 3 is the default.
		STARTUP PROGRAM	Select 1, 2, or 3	
	FLIP DISPLAY	ENABLE	-	Standard control panel display.
		DISABLE	-	Flips control panel display.
	DISPLAY SAVER	DISPLAY DIM	-	Dims OLED display when control panel is not in use.
		DISPLAY OFF	-	Turns off OLED display when control panel is not in use.
	FAN MODE	STANDARD	-	
		SILENT	-	
		MAX POWER	-	

Level 1	Level 2	Level 3	Level 4	Function
SETTINGS (continued)	MINIMUM VALUES	RED (Q-2)	-	Sets minimum values for individual segments.
		GREEN (Q-2)	-	
		BLUE (Q-2)	-	
		WHITE (Q-2/Q-2 W)	-	
	FACTORY DEFAULT	-	-	Restores factory default.
	SERVICE PIN	-	-	Service use only.
	SERVICE MENU	-	-	Service use only.

Level 1	Level 2	Level 3	Level 4	Function
MANUAL	QUICK COLOR	RED (Q-2)	-	Static quick color - red mix (0-255). Sets fixture to quick color startup mode.
		GREEN (Q-2)	-	Static quick color - green mix (0-255). Sets fixture to quick color startup mode.
		BLUE (Q-2)	-	Static quick color - blue mix (0-255). Sets fixture to quick color startup mode.
		WHITE (Q-2/Q-2 W)	-	Static quick color - white mix (0-255). Sets fixture to quick color startup mode.
	RUN PROGRAM	1, 2, OR 3	-	
	STOP PROGRAM	-	-	
	EDITOR	PROGRAM	-	Currently selected program (1, 2, or 3).
		SCENE	-	Currently selected scene (1-24).

Level 1	Level 2	Level 3	Level 4	Function
MANUAL (continued)	EDITOR (CONTINUED)	RED (Q-2)	-	Red value in currently selected scene (0-255).
		GREEN (Q-2)	-	Green value in currently selected scene (0-255).
		BLUE (Q-2)	-	Blue value in currently selected scene (0-255).
		WHITE (Q-2/Q-2 W)	-	White value in currently selected scene (0-255).
		SHUTTER	Adjust (0-255)	Blackout (0-7)
				Open (8-15)
				Variable Strobe (16-151)
				Pulse Open (152-175)
				Pulse Close (175-199)
				Variable Random Strobe (200-244)

Level 1	Level 2	Level 3	Level 4	Function
MANUAL (continued)	EDITOR (continued)	SHUTTER (continued)	Adjust (0-255)	Open (245-255)
		FADE TIME MIN.	-	Fade-in (transition) time to current scene in minutes (0-511).
		FADE TIME SEC.	-	Fade-in (transition) time to current scene in seconds (0-59).
		WAIT TIME MIN.	-	Wait (static) time to current scene in minutes (0-998).
		WAIT TIME SEC.	-	Wait (static) time to current scene in seconds (0-59).
TEST	SELFTEST	-	-	Executes burn-in test.
	DISPLAY TEST	-	-	Executes display test.
	COLOR TEST	-	-	Executes color test.

Fixtures and accessories

Included items

Floor stand (including screws)
Omega bracket
User manual
Neoprene pouch

Ordering information

Q-2 Color Flood Light	Order no: 80030535
Q-2 White	Order no: 80030536
SGM USB uploader cable	Order no: 83062011
Accessory holder	Order no: 83061128
Barn door 4-way	Order no: 83061129
Barn door 8-way	Order no: 83061130
Color frame	Order no: 83061131
Omega bracket	Order no: 83060602
Flight case (for 4 fixtures incl. barn doors)	Order no: 82051503

APPROVALS AND CERTIFICATIONS

Certified toCSA E60598-1:02, Ed: 2
Certified to CSA-E598-2-17-98, Ed: 1
Conforms to UL Std. 1573
Conforms to 2004/108/EC: EMC Directive
Conforms to 2006/95/EC: Low Voltage Directive
Conforms to2011/65/EU: RoHS2 Directive



The information in this document is subject to change without notice

User's notes



SGM A/S · Sommervej 23 · 8210 Aarhus V · Denmark
Tel +45 70 20 74 00 · info@sgmlight.com · www.sgmlight.com